

## KL-0680-80 K

KN 9.71

# INJECTOR NOZZLE PULLER IN A PLASTIC STORAGE CASE, FORD ECOBLUE 2.0

**Applicable to Ford 2.0 EcoBlue Diesel engines.**

**Fitted to:** Ford Transit (2014 onwards) and Transit Custom (2012 onwards) etc.

**Alternative tool:** Ford 303-1690/1 + 303-1690/2 and 303-1690 respectively.

Allows for removing stuck/tight-fitting injector nozzles in situ on the vehicle, without having to dismantle the cylinder head.

**Procedure:**

Unscrew injector top part. Screw pull spindle into injector bottom part. Slide support sleeve over pull spindle and screw on shoulder nut. Remove injector by turning shoulder nut.

**Additional accessory:** Puller for Sealing Ring **KL-0369-59**  
(Alternative tool: Ford 303-1690/3)

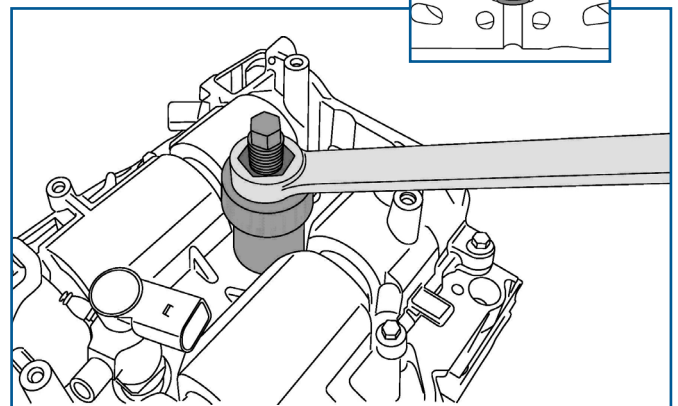
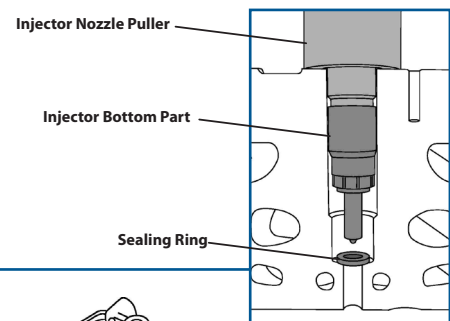

**Scope of Delivery:**

Pos.	Part No.	Description	Qty
-	KL-0680-80 K	Injector Nozzle Puller in a Plastic Storage Case, Ford EcoBlue 2.0	1
<i>consists of:</i>			
1	KL-1383-1112	Shoulder Nut, M16x1.5	1
2	KL-0680-8002	Pull Spindle, M17x0.75, 200mm long	1
3	KL-0680-800	Support Sleeve with Bearing	1
4	KL-0680-8011	Injector Removal Socket	1
-	KL-0680-8090	Plastic Storage Case	1

\* All information and prices are subject to typographical and printing errors.

0680-80Ke190521