

## KL-0187-100 E, Code 3283798

KN 9.93

# INJECTOR EXTRACTOR KIT FOR DIRECT INJECTION PETROL ENGINES, IN FOAM INSERT

**Fits universally for passenger cars and vans with direct injection petrol engines with BOSCH, SIEMENS VDO, CONTINENTAL, MAGNETI-MARELLI, and DENSO injectors. Installed for example on VW-Audi, Seat, Škoda (FSI, TSI, TFSI), Alfa Romeo, BMW, Ford, Hyundai, Nissan, Mercedes, Opel, and many more.**

For quick and professional removal of injectors on direct injection petrol engines. Required, for example, when replacing the injectors and when dismantling the valve cover.

For this, the injector is loosened and pulled out using the impact extractor. The different extractors allow safe operation on the respective injector.

**Alternative tools:**

VW T10133, T10133/1, T10133/2, T10133/3, T10133/9; BOSCH 0986616101; Ford 205-047, 205-047-08, 310-206; Nissan KV10119600; Opel / Vauxhall J-37281-A

**Recommended accessories:**

**KL-0187-101** - Injector repair kit

**Storage system:**

**KL-4990-9274** - Plastic case



Made in Germany

**Scope of delivery:**

Item	Part no.	Description	Quantity
-	KL-0187-100 E	Injector extractor kit for direct injection petrol engines, in foam insert	1
<i>consisting of:</i>			
1	KL-0187-1001	Extractor for impact hammer size 1	1
2	KL-0187-1002	Extractor for impact hammer size 2	1
3	KL-0187-1003	Extractor for impact hammer size 3	1
4	KL-0187-1004	Extractor for impact hammer size 4	1
5	KL-0187-1005	Extractor for impact hammer size 5	1
6	KL-0049-1205	Plastic sleeve	1
7	KL-0049-101	Impact extractor base unit	1
-	KL-0187-1090	Foam insert	1

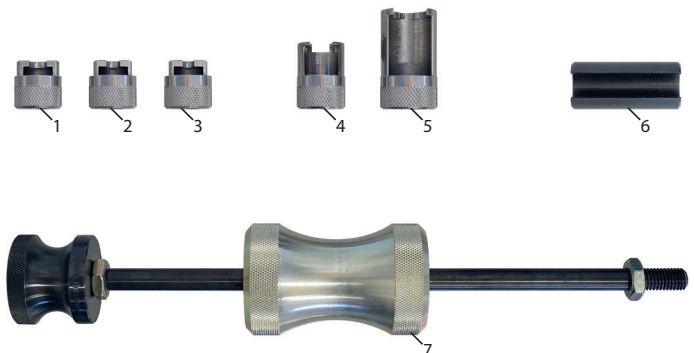

\* All information and prices are subject to typographical and printing errors.

## KL-0187-101, Code 3283828

KN 9.93

# INJECTOR REPAIR KIT FOR DIRECT INJECTION PETROL ENGINES

**Fits universally for passenger cars and vans with direct injection petrol engines with BOSCH, SIEMENS VDO, CONTINENTAL, MAGNETI-MARELLI, and DENSO injectors. Installed for example on VW-Audi, Seat, Škoda (FSI, TSI, TFSI), Alfa Romeo, BMW, Ford, Hyundai, Nissan, Mercedes, Opel, and many more.**

For damage-free assembly of combustion chamber sealing rings (Teflon sealing rings), and O-rings (fuel side) on direct injection petrol injectors. Before reinstalling a used injector, replace the sealing rings as specified by the manufacturer. The new sealing rings are simply pushed on the injector via the assembly cone with the aid of the calibration tool. The sealing ring for the combustion chamber is additionally constricted (calibrated) in 2 stages at the seal-seat. A new combustion chamber sealing ring which was not constricted during the installation will most probably be damaged when re-installing the injector.

#### Alternative tools:

VW T10133, T10133/5, T10133/6, T10133/7, T10133/8; BOSCH 0986616097; BMW 130280, 130281, 130282, 130283, 130190, 130192, 130193, 130194, 130195; Opel / Vauxhall EN-48266, 48266-1, 48266-2; Ford 310-128; Hyundai 09353-2B000; NISSAN / INFINITI KV101197S0

#### Recommended accessories:

**KL-0187-100 E** - Injector extractor kit for direct injection petrol engines

#### Storage system:

**KL-4990-9274** - Plastic case,

**KL-0187-1090** - Foam insert

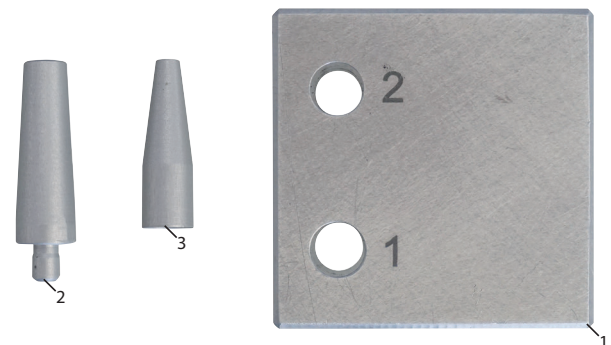

Made in Germany

#### Scope of delivery:

Item	Part no.	Description	Quantity
-	KL-0187-101	Injector repair kit for direct injection petrol engines	1
consisting of:			
1	KL-0187-1011	Calibration tool	1
2	KL-0187-1012	Mounting cone	1
3	KL-0187-1013	Mounting cone	1

\* All information and prices are subject to typographical and printing errors.

0187-100E\_101\_EN210301

**GEDORE Automotive GmbH**  
Breslauer Straße 41  
78166 Donaueschingen - GERMANY

T +49 0771 83223-0  
F +49 0771 83223-90  
info.gam@gedore.com  
www.gedore-automotive.com

**Brands of the GEDORE Group**  
gedore.com  
ochsenkopf.com

formerly **KLANN**